

carpenteria in ferro - impianti industriali

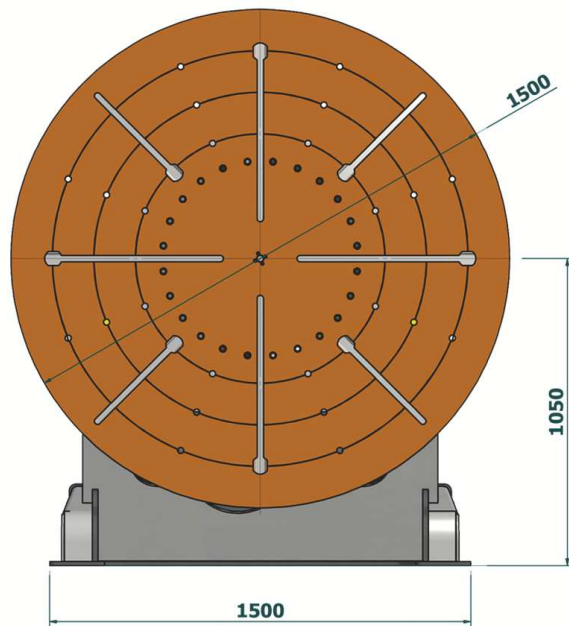

Portata Max tavola orizzontale:	6.000 Kg
Portata Max in tutte le posizioni - 0°/110°:	3.000 Kg
momento torcente Max :	1.500 Kg/m
momento flettente Max :	3.000 Kg/m
Velocita' rotazione tavola:	0,15 - 0,5 RPM
Inclinazione tavola:	0° - 105°
Peso della macchina:	3.000 Kg
Tensione di alimentazione:	380V 50Hz 3f
Potenza installata:	4,0 Kw
Massa per saldatura:	1.000 A

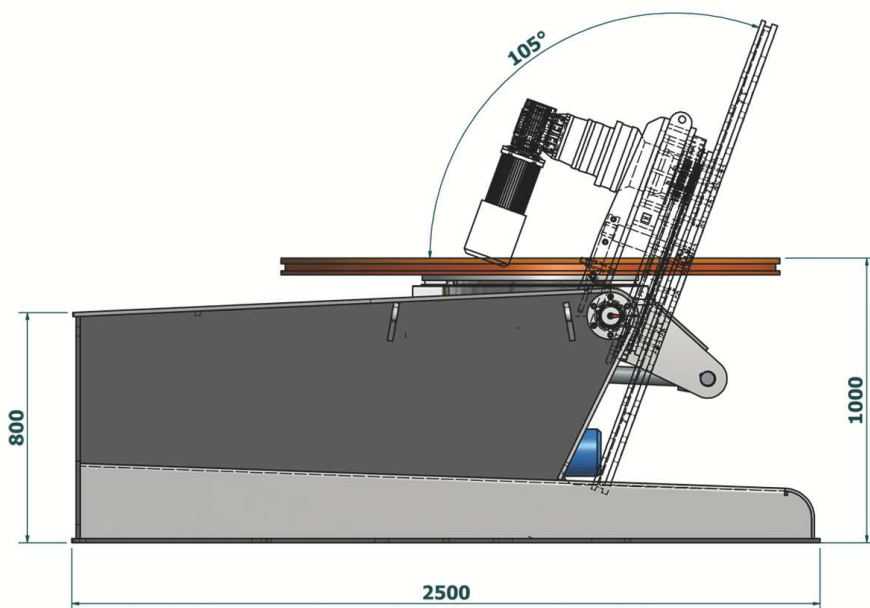