

carpenteria in ferro - impianti industriali

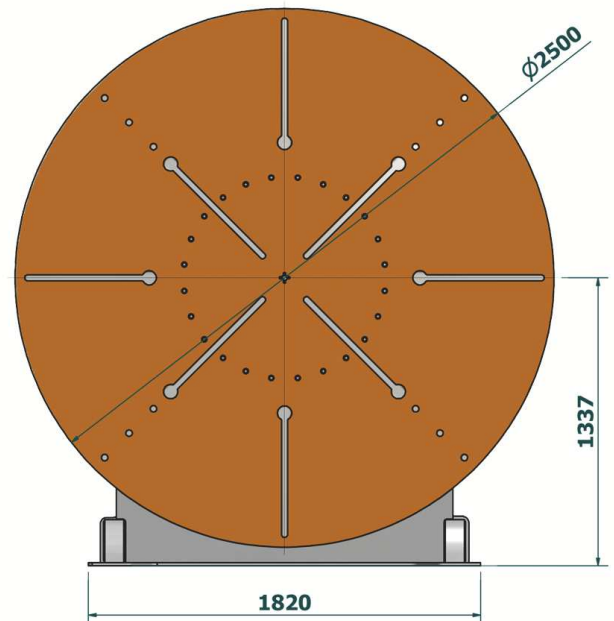

Portata Max tavola orizzontale:	20.000 Kg
Portata Max in tutte le posizioni - 0°/110°:	10.000 Kg
momento torcente Max :	2.000 Kg/m
momento flettente Max :	10.000 Kg/m
Velocita' rotazione tavola:	0,02 - 0,4 RPM
Inclinazione tavola:	0° - 110°
Peso della macchina:	6.000 Kg
Tensione di alimentazione:	380V 50Hz 3f
Potenza installata:	8,0 Kw
Massa per saldatura:	2.000 A

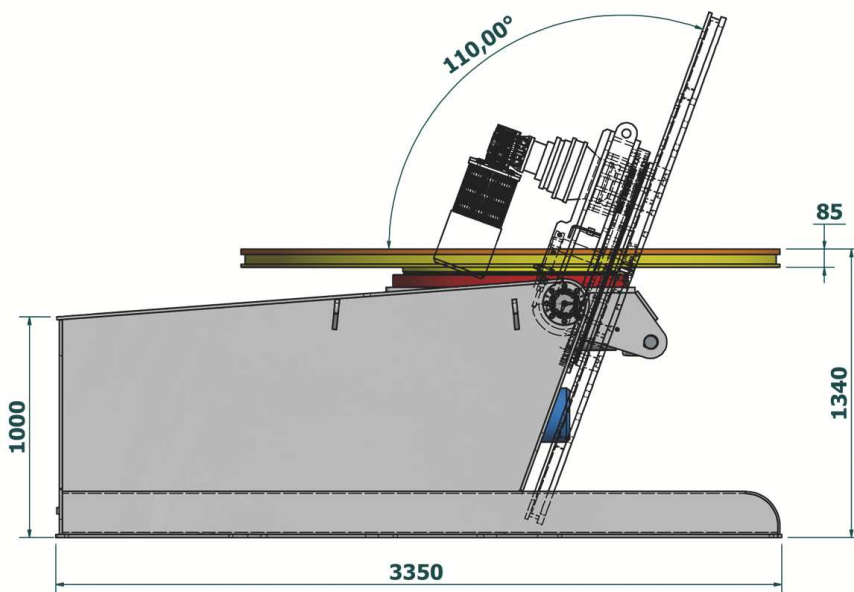